

Operation Manual: KB-522 & KB-522-SS Pressure Feed Cup



E	P 1 - 12
---	----------

Operation Manual: KB-522 & KB-522-SS Pressure Feed Cups

Important: Read and follow all instructions and **SAFETY PRECAUTIONS** before using this equipment.

The KB-522 pressure feed cup incorporates an air regulator, safety valve, pressure relief valve, pressure gauge and a carrying handle. An additional bail handle is also supplied to enable the user to suspend the cup from a belt or other device. Hose assemblies to connect the spray gun to the cup are not included and should be ordered separately, see 'Accessories'.

Corrosion resistant version also available with Stainless Steel Cup and plated Lid.

Order No.

KB-522 STD CUP

KB-522-SS STAINLESS STEEL CUP

EC Declaration of Conformity

We: **ITW Finishing UK, Ringwood Rd, Bournemouth, Dorset, BH11 9LH, UK**, as the manufacturer of the

Pressure Cup models KB-522 & KB-522-SS

declare, under our sole responsibility, that the equipment to which this document relates is in conformity with the following standards or other normative documents:

EN 13463-1:2001; and thereby conform to the protection requirements of Council Directive **94/9/EC** relating to **Equipment and Protective Systems intended for use in Potentially Explosive Atmospheres protection level II 2 G X**, suitable for use in ZONE 1 hazardous areas.



B. Holt, General Manager
9th February 2004



SAFETY WARNINGS



Fire and explosion

Solvents and coating materials can be highly flammable or combustible when sprayed. **ALWAYS refer to the coating material suppliers instructions and COSHH sheets before using this equipment**



Users must comply with all local and national codes of practice and insurance company requirements governing ventilation, fire precautions, operation and house-keeping of working areas



FOR KB-522 ONLY:

Do not use Solvents or coating materials containing HALOGENATED HYDROCARBONS with this equipment.

FOR KB-522-SS ONLY:

This equipment, as supplied, is suitable for use with Halogenated Hydrocarbons and the user must ensure that all other equipment in the system is also suitable for use with these materials. **DO NOT SPRAY MATERIALS CONTAINING THESE SOLVENTS EXCEPT WITH EQUIPMENT SPECIFICALLY DESIGNATED BY THE MANUFACTURER AS BEING SUITABLE FOR SUCH USE.**



Static Electricity can be generated by fluid and/or air passing through hoses, by the spraying process and by cleaning non-conductive parts with cloths. To prevent ignition sources from static discharges, earth continuity must be maintained to the spraygun and other metallic equipment used. It is essential to use conductive air and/or fluid hoses.

Personal Protective Equipment



Toxic vapours – When sprayed, certain materials may be poisonous, create irritation or be otherwise harmful to health. Always read all labels and safety data sheets for the material before spraying and follow any recommendations. **If In Doubt, Contact Your Material Supplier**



The use of respiratory protective equipment is recommended at all times. The type of equipment must be compatible with the material being sprayed.



Always wear eye protection when spraying or cleaning the spraygun



Gloves must be worn when spraying or cleaning the equipment



Training

Personnel should be given adequate training in the safe use of spraying equipment.

Misuse

- Never aim a spraygun at any part of the body. Never exceed the max. recommended safe working pressure for the equipment.
- The fitting of non-recommended or non-original spares may create hazards.
- Before cleaning or maintenance, all pressure must be isolated and relieved from the equipment.
- Never exceed the recommended safe working pressures for any of the equipment used.
- Never drill into or modify the pressure feed cup in any way.
- Do not adjust, remove or tamper with the safety valve. If a replacement is necessary, only use DeVilbiss supplied spare Valves.
- The materials used in the construction of the cup are (bearing in mind the warning on Halogenated Hydrocarbons) solvent resistant enabling the cup to be cleaned using gun washing machines. However, the lid assembly must not be cleaned in a gun washing machine as it contains parts that will be damaged.

Parts List

Ref.	Order No.	Description	Qty.
1	KB-64	Retaining Ring	1
2	KB-81-K5	Slip Rings	1
3	KB-74	Handle	1
4	SS-656-CD	CD Nut	1
5	JGA-158	Connector 1/4" BSP	2
6	KB-66	Pressure Relief Valve	1
7	-	Lid	1
8	GA-355	Gauge	1
9	KB-80-K5	Seal	1
10	MBD-11-K5 KB-97-K2	Locknut (KB-522) kit of 5 Locknut -Stainless Steel (KB-522-SS) kit of 2	1
11	KB-422 KB-442	Cup – Aluminium (KB-522) Cup – Stainless Steel (KB-522-SS)	1
12	KB-432-K3	Check Valve kit of 3	1
13	KB-85-K5	Seal kit of 5	1
14	TIA-4355	Safety Valve	1
15	KB-428-1	Regulator Assembly	1
*16	-	Spring	1
*17	-	Valve	1
*18	-	Valve Seat and Seal	1
*19	-	Diaphragm	1
*20	-	Slip Ring	1
21	-	Spring	1
*22	-	Bonnet	1
23	KB-60-K6	Seal kit of 6	1
24	KK-4997	Tube Assembly (KB-522)	1
	KK-4996	Tube Assembly (KB-522-SS)	1
25	KB-444	Check Valve and Seal Assembly	1
26	KB-101-K5	Seal kit of 5	1

Note: Ref No.s marked * are supplied in repair kit **Order No. KK-4887-2.**

View showing position of internal check valve parts

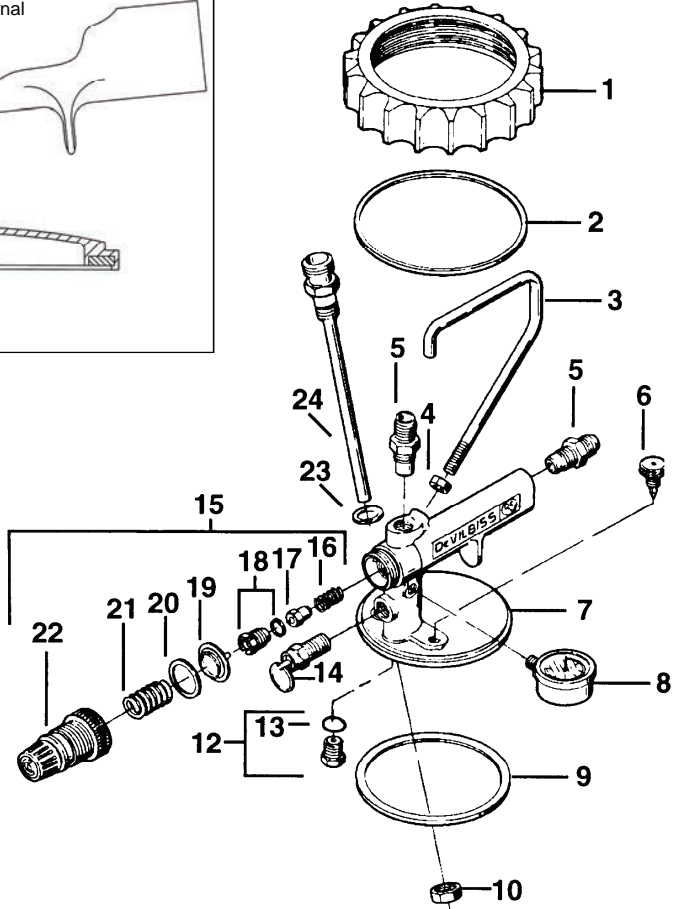
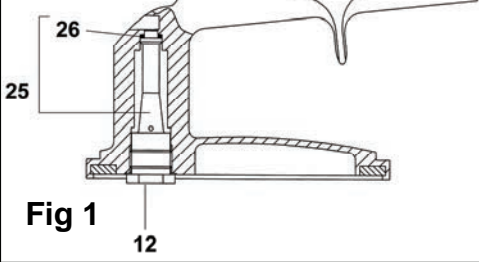
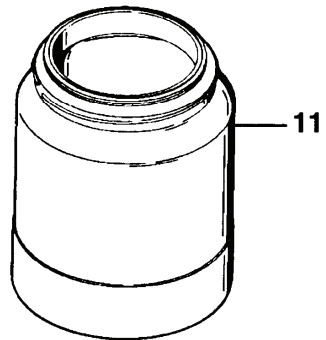
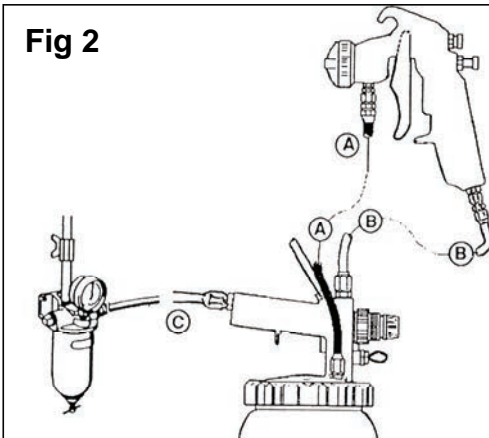

Fig 2



Specification

Hose connections

Air	: 1/4" Universal
Fluid	: 3/8" Universal
Maximum Working Pressure	: 2.1 Bar (30 lbf/in ²)
Maximum Air supply pressure	: 8.6 Bar (125 lbf/in ²)
Height	: 183 mm (7 3/16")
Weight (dry)	: 1.76 kg (3 lb 14 oz)
Capacity	: 2 Litres

PARTS IN CONTACT WITH COATING MATERIAL:

	522	522-SS
Cup	: Aluminium Alloy	Stainless Steel
Cup Lid	: Aluminium Alloy	Aluminium Alloy Nickel Plated
Lid Seal	: Santoprene	Santoprene
Tube	: Aluminium Alloy	Stainless Steel
Tube Nut	: Brass Nickel Plated	Stainless Steel
Check Valves	: Acetal, Brass and S.S	Acetal, Brass and S.S
Pressure Relief Valve	: Brass Nickel Plated	Brass Nickel Plated

Installation

IMPORTANT: To ensure that this equipment reaches you in first class condition, protective coatings, rust inhibitors, etc., have been used. Flush all equipment through with a suitable solvent before use to remove these agents from the material passages.

1. Connect the coating material hose (Fig 2, A) from the cup outlet to the gun.
2. Connect the air hose (B) from the cup outlet to the gun.
3. Connect the air supply hose (C) to a filtered/regulated air supply and to the cup inlet.

Operation

CAUTION: The cup is under pressure. Disconnect the air supply and release the pressure in the cup assembly before removing the cup from the lid assembly or disconnecting the gun or the material hose. Never allow the cup to lay on its side or fall over when it contains material.

Controls (See Figure 1)

- **Safety Valve (14):** The safety valve limits the maximum air pressure to the cup. If the safety valve does not work properly, over pressurisation may occur and cause the cup to rupture or explode. Occasionally pull the ring on the safety valve and make sure that it operates freely. If the valve is stuck or does not operate smoothly it must be replaced with a valve having the same rating. Never attempt to adjust or dismantle the safety valve.
- **Regulator (15):** Controls the pressure of the coating material in the cup. To increase the

pressure, pull knob out, turn the knob in the direction of the arrow shown on the knob, to reduce pressure turn in the opposite direction. When pressure is set push knob in to lock.

- **Pressure Relief Valve (6):** Vents the air pressure in the cup. To open, turn valve counter-clockwise. **CAUTION** Do not unscrew the pressure relief valve (6) completely when relieving the pressure as it may have sufficient air pressure to eject the valve from the lid creating a hazard.
- **Pressure Gauge (8):** Indicates the air pressure in the cup. Do not attempt to remove the cup (15), spray gun or coating material hose if the gauge indicates pressure in the cup.

NOTE: Regularly check that the pressure gauge is reading correctly.

1. Mix, prepare and filter the coating material to be sprayed according to the manufacturer's instructions.

- | | |
|----------------------------------------------------------------------------------------------------------------------------------------------------------------------------------------------------------------------------------------------------------------------------------------------------------------------------------------------------------------------------------------------------------------------------------------------------------------------------------------------------------------------------------------------------------------------------------------------------------------------------------------|----------------------------------------------------------------------------------------------------------------------------------------------------------------------------------------------------------------------------------------------------------------------------------------------------------------------------------------------------------------------------------------------------------------------------------------------------------------------------------------|
| <ol style="list-style-type: none"> 2. Adjust the spray gun controls as described in the Operation Manual supplied with the gun. 3. Turn the regulator knob (15) to the minimum pressure and open the pressure relief valve (6) to vent any pressure in the cup. 4. Remove cup (11) by turning ring (1) counter-clockwise and fill with the coating material, DO NOT OVERFILL. (If using the liner Kit KK-5051, see section on liner fitting) 5. Replace lid assembly on cup, push down with the handle and tighten ring (1). 6. Close the pressure relief valve (6), turn on | <p>and adjust the supply air pressure to 3.5 bar (50 lbf/in²).</p> <ol style="list-style-type: none"> 7. Adjust the material pressure to 0.7 bar (10 lbf/in²). 8. Test spray, adjust atomisation and material pressures to suit required application rate. <p>NOTE: To reduce the material pressure turn regulator (15) down and open the pressure relief valve (6). Close relief valve (6), and readjust the regulator (15).</p> |
|----------------------------------------------------------------------------------------------------------------------------------------------------------------------------------------------------------------------------------------------------------------------------------------------------------------------------------------------------------------------------------------------------------------------------------------------------------------------------------------------------------------------------------------------------------------------------------------------------------------------------------------|----------------------------------------------------------------------------------------------------------------------------------------------------------------------------------------------------------------------------------------------------------------------------------------------------------------------------------------------------------------------------------------------------------------------------------------------------------------------------------------|

Preventative Maintenance

CLEANING

DO NOT clean the cup lid assembly in a gun washing machine as the safety valve (18), gauge (6) and regulator (19) contain parts that will be damaged.

1. Disconnect the air supply and relieve the pressure in the cup.
2. Remove the cup (11) and empty surplus coating material. Wipe the lid and the inside of the cup clean.
3. Fill the cup with a small quantity of compatible solvent and refit. Connect the air supply,

spray the solvent until clean.

4. Disconnect the air supply and relieve the pressure in the cup.
5. Remove the cup (11), empty the residual solvent and dry internal surfaces.
6. Inspect that the check valve (12) and pressure relief vent holes in the lid are free from coating material.

NOTE: The check valve cap may be unscrewed to aid inspection and cleaning, **DO NOT** dismantle any further.

Service Checks

CONDITION	CAUSE	CORRECTION
A Erratic regulation or excess pressure in the cup	1 Regulator valve (17, 18) leak	Replace
	2 Gauge (8) reading incorrectly	Replace
	3 Safety valve (14) faulty	Replace
	4 Regulator Spring (21) broken or distorted	Replace
	5 Regulator diaphragm (19) damaged	Replace
B Insufficient pressure in the cup	1 Check valve (12) jammed.	Clean/replace.
	2 Safety valve faulty.	Replace
	3 Gauge (8) reading incorrectly	Replace
	4 Air leakage at cup lid	Tighten ring (1), replace Seal (9) or Slip Ring (2)

KK-5051 DISPOSABLE CUP LINER

The DeVilbiss Liner system creates a barrier between the coating material and the cup, avoiding lengthy cleaning procedures and saving solvent. The liner can be used with any coating material that is compatible with polyethylene.

Each kit consists of 20 Liners, 20 Lids and 3 Rings

Installation Instructions

Liner Kit Parts

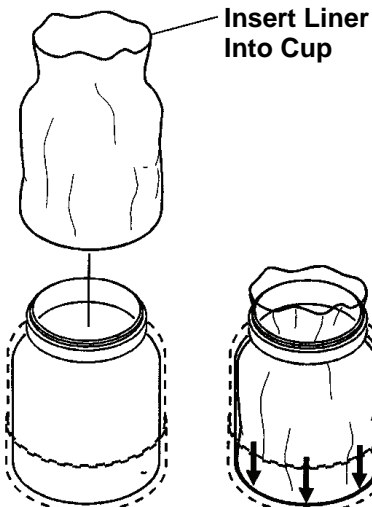
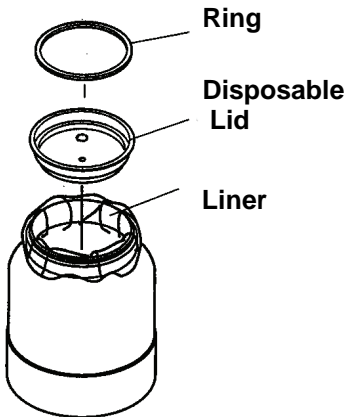

1

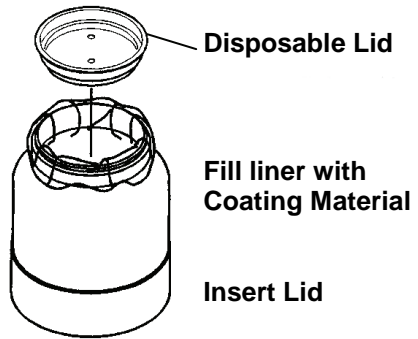

2

Wrap Liner Over Lid

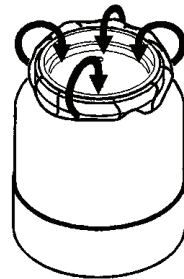

3

Place Ring
Inside Cup

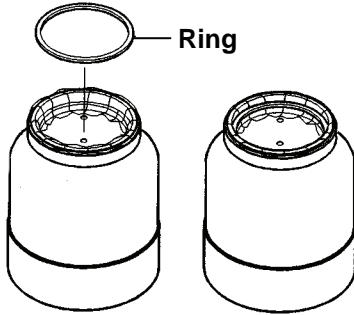

4

Slide Fluid Tube
through opening
and assemble Lid
to cup

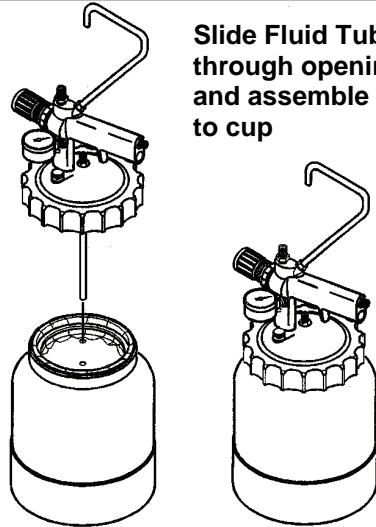

5

Disassembly/Cleaning Instructions

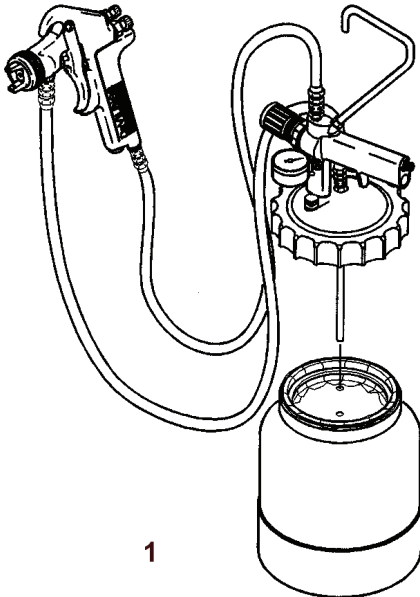

1

Disassemble Cup Lid.
Withdraw the tube slowly to allow
the paint inside the tube to drain.
Catch excess paint with rag.

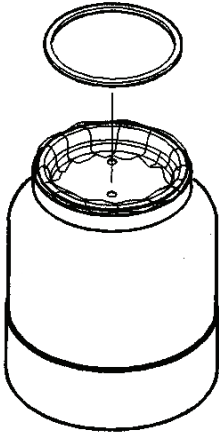
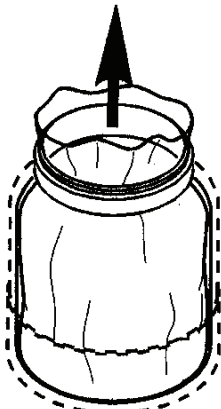
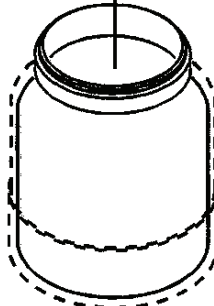
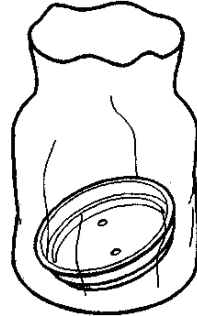
Remove Ring**2****Pull up on Liner****3****Properly Dispose of Lid,
Liner and waste material.
Retrieve Ring****4**

NOTES

Accessories

Hose Assemblies to connect cup to spraygun:

Order No. H-6066-N Air hose 8 mm bore 1.2 m long with 1/4" connections

H-6067-N Coating material hose 6 mm bore 1.4 m long with 3/8" connections.

Other accessories;

Order No. KB-435 Conversion Kit for 50 psi maximum working pressures version.

KK-5051 Liner Kit of 20 Liners

ITW Finishing Systems and Products
Ringwood Road,
Bournemouth,
BH11 9LH,
England.
Tel. No. (01202) 571111
Telefax No. (01202) 581940,
Website address <http://www.itweuropeanfinishing.com>

ITW Finishing Systems and Products is a Division of ITW Ltd. Reg. Office:
Admiral House,
St Leonard's Road,
Windsor,
Berkshire,
SL4 3BL,
UK
Registered in England: No 559693 Vat No 619 5461 24